

*G. S. Knight.*

*Turning Axles.*

*N<sup>o</sup> 67,886.*

*Patented Aug. 20, 1867.*

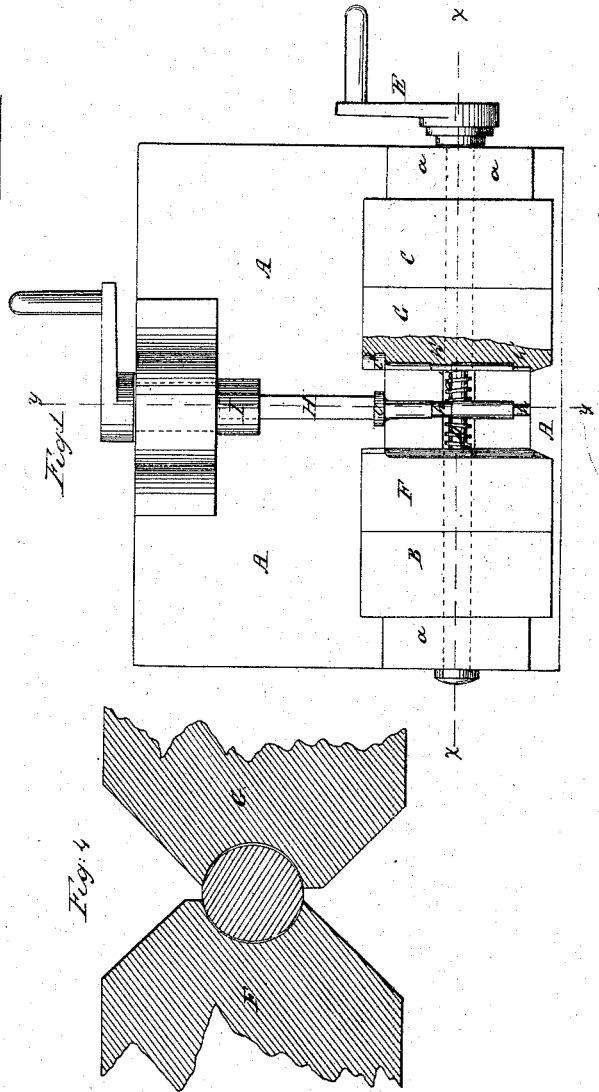
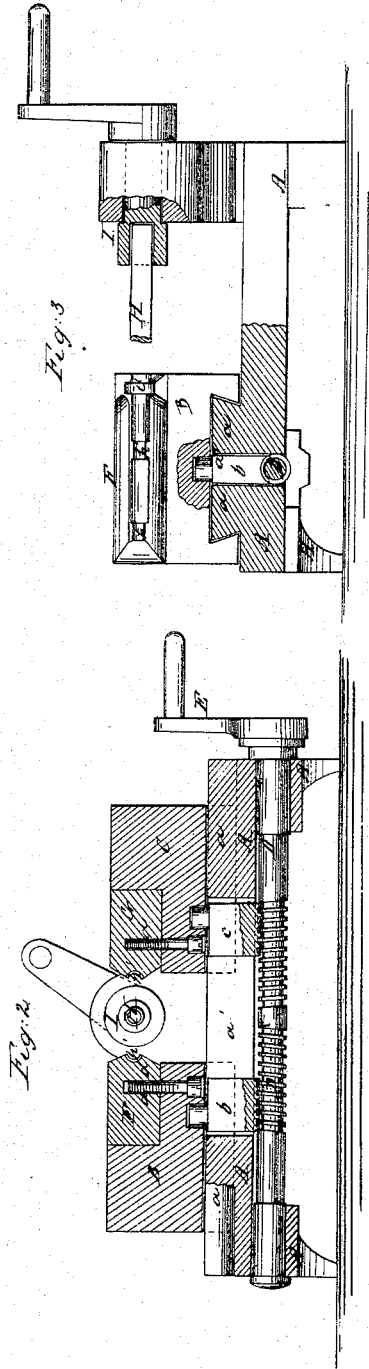

*Witnesses:*  
*Edw. Trench*  
*J. A. Jackson*

*Inventor:*  
*Ges. S. Knight*  
*Per Munnell & Co.*  
*Attorneys*

# UNITED STATES PATENT OFFICE.

GEORGE S. KNIGHT, OF SYRACUSE, NEW YORK.

## IMPROVED MACHINE FOR TURNING AXLES.

Specification forming part of Letters Patent No. 67,886, dated August 20, 1867.

*To all whom it may concern:*

Be it known that I, GEORGE S. KNIGHT, of Syracuse, in the county of Onondaga and State of New York, have invented a new and Improved Machine for Turning Axles; and I do hereby declare that the following is a full, clear, and exact description thereof, which will enable others skilled in the art to make and use the same, reference being had to the accompanying drawings, forming part of this specification.

This invention relates to a machine in which axles and shafting, of whatever description and form, can be turned in a very accurate and rapid manner, and by means of which any rings or grooves around such an axle or shaft can be very neatly and accurately executed.

My invention consists in applying to a common lathe, or to any other machinery in which the axle to be turned can be held and revolved, a pair of jaws, connected each or only one with appropriate cutters, by which the axle will receive its desired shape. These jaws are brought together, as far as necessary, by means of a right and left hand screw, or by cams or any other suitable device.

This machine will be found very practicable, as it can be applied without much expense to any kind of machinery in which a pulley is revolved, and as it is very compact in its form and very substantial and durable in structure, it will be found to be a very acceptable device for all those who may have occasion to use it.

Having stated the nature of my invention, I will now proceed to describe its construction and operation, whereby all those skilled in the art will be enabled to make and use the same, reference being had to the accompanying drawing, in which—

Figure 1 represents a plan or top view of my improved machine, partly in section. Fig. 2 is a vertical cross-section of the same, taken on the line *x x*, Fig. 1. Fig. 3 is a vertical longitudinal section of the same, taken on the line *y y*, Fig. 1. Fig. 4 is a full-size cross-section, showing the jaws and knives and the axle which is being turned.

Similar letters of reference indicate like parts.

A represents a solid platform, made of metal, by which all the other parts of my machine

are held and supported. Upon its top is secured a track, *a*, the sides of which incline inward toward the bottom, so that the jaws B and C, which slide on this track, can only move toward or from each other in a straight line. Up and down as well as side motion of them is effectually prevented.

The jaws are moved by means of a right-and-left screw, D, which works in nuts *b* and *c*, so that when the screw is turned by means of the crank E the jaws will be either moved together or apart simultaneously, as may be desired. A stop, consisting of an adjustable screw or pin, may be attached to one of the jaws, so that they cannot be brought closer together than is necessary. The nuts *b* and *c* travel in a slot, *a'*, in the platform A, and when striking against the end of this slot prevent the jaws from being brought too far apart.

To each of the jaws is secured by means of screws *d*, or by any other suitable device, a cutter, F and G. These cutters are so arranged that they will impart to the axle the shape required. As is seen in Figs. 2 and 3, these cutters are provided with grooves conforming to the required shape of the axle—that is to say, whenever there is a groove, *h*, to be around the axle, a corresponding projection or ring, *h'*, is left in the cavity of the cutter; and wherever there is a projection or ring, *i*, to be left on the axle, a corresponding groove, *i*, in the cavity of the cutters is provided, Figs. 1 and 3.

The cutters cut each with one edge only, the cutter F with the lower, the cutter G with the upper edge only. The axle H is placed within the spindle I of any ordinary lathe or other machine. The axle has previously to be forged or swaged with the necessary taper and with the ring or shoulder on it, and is then placed into the spindle to be turned.

The jaws are brought together near enough to enable the cutting-edge to operate on the axle, and are gradually brought closer together until the axle is turned enough, or until it has the necessary thickness. The jaws are then drawn apart, and the axle is taken out to be replaced by a new one.

The cutters are made substantial and compact, and will last a long time before they need

regrinding. If required or found practicable, one of the jaws may be made movable only; or to one of the jaws may only be attached the cutters; or the cavities in the cutters may be square or V-shaped instead of circular; or only one of the jaws may be provided with such a cavity or groove, while to the other is secured the cutter. In case but one jaw is movable, a cam may be employed instead of the screw D to press the jaw against the axle; but even if both the jaws are movable well-adjusted cams may be employed instead of the screw.

Having thus described my invention, what I claim as new, and desire to secure by Letters Patent, is—

An improved machine for turning axles and shafting composed of the movable jaws B and C, cutters or clamp-mills F and G, and screw D, or their respective equivalents, all made, arranged, and operating substantially as and for the purpose herein shown and described.

The above specification of my invention signed by me this 19th day of October, 1866.

GEO. S. KNIGHT.

Witnesses:

WM. F. MCNAMARA,  
ALEX. F. ROBERTS.